

*Frontiers 2011
April 27, 2011*

Vendor Panel Discussion: Advances in Model-Based Systems Engineering

Dirk Zwemer, PhD
President, InterCAX LLC
dirk.zwemer@intercax.com



- **Advances and Challenges**
- **Customer Benefits and Issues**
- **Opportunities**

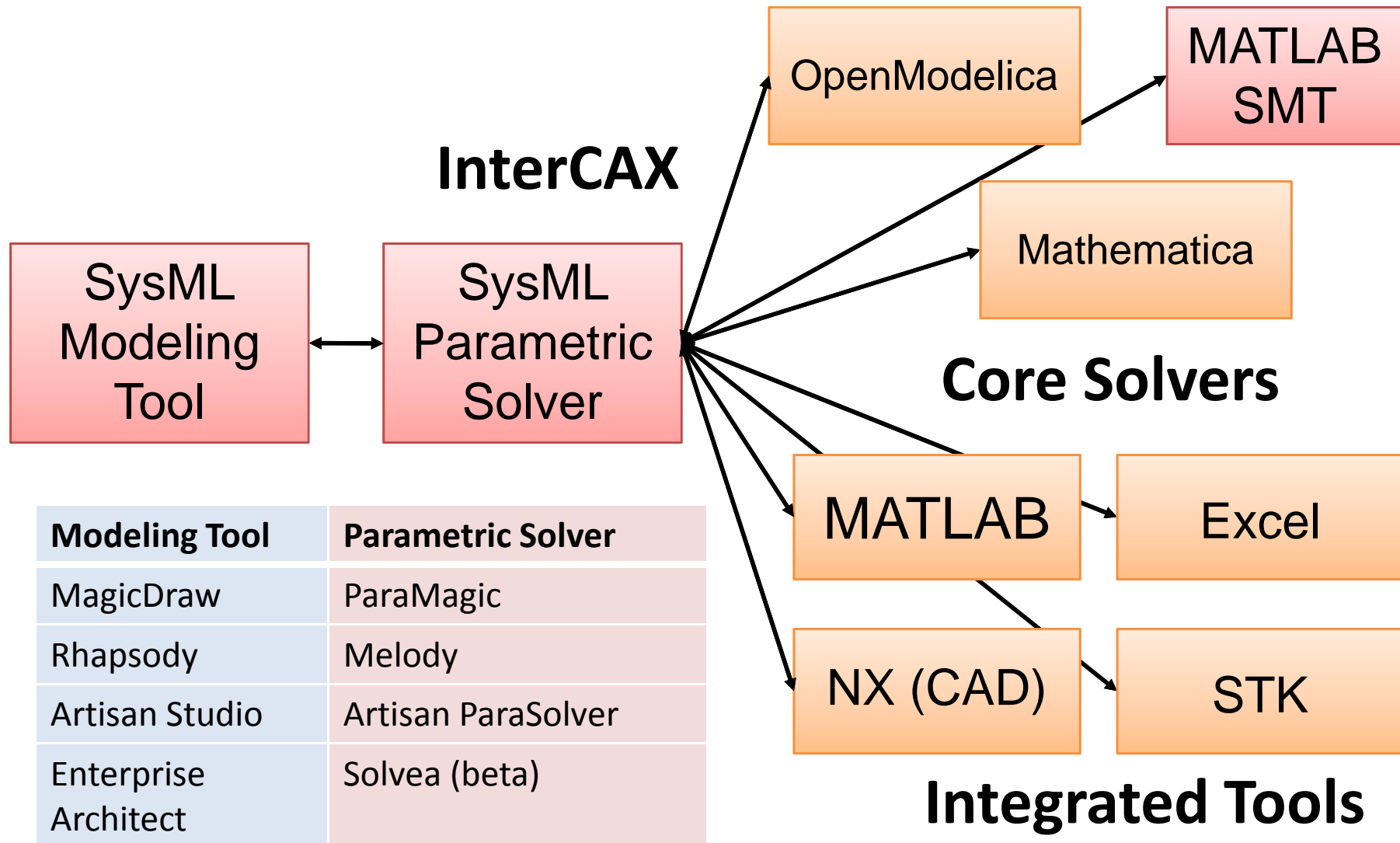

Collaborative System M&S Framework InterCAX LLC

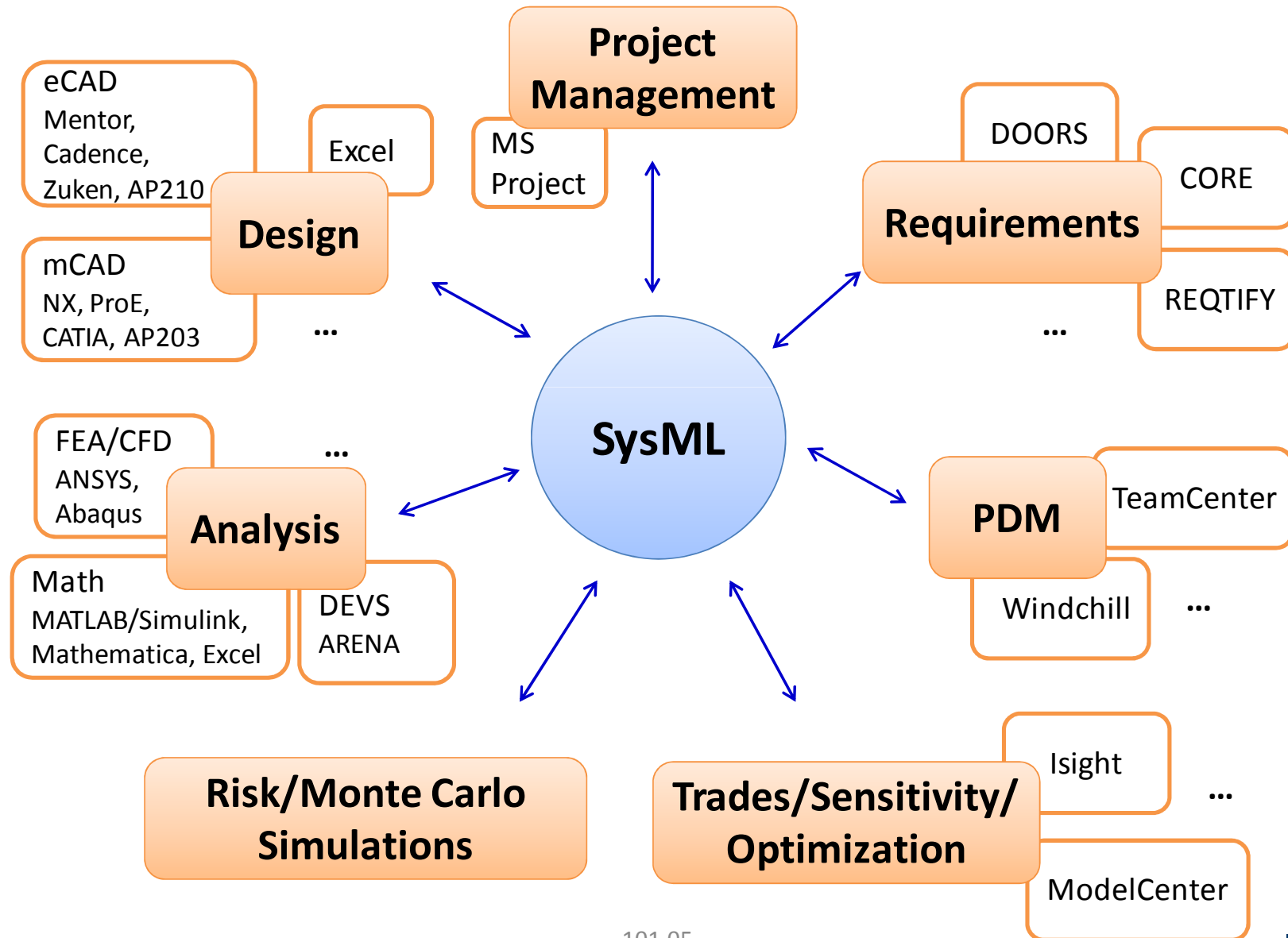

- Transfer Data between Independent Models

- SysML-Excel

- Function calls from SysML to MATLAB

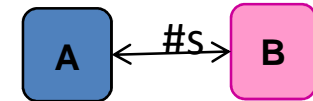

- Transform Model from Tool A to Tool B

- SysML parasolvers export constraint network

- SysML-Modelica, SysML-Simulink

- Multistep variations, e.g. CAD-FEA

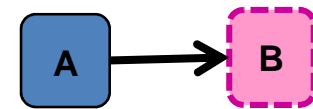

- Mirror Model from Tool B in Tool A

- SysML-CAD

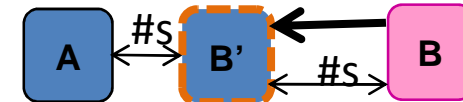

- More Complex Patterns

- Intermediate models and repositories

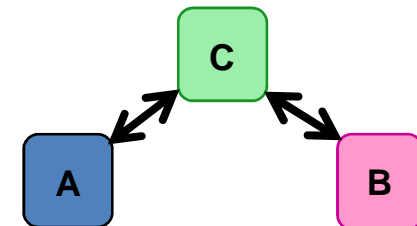

- General Systems Engineering
 - User Interface Efficiency
 - Effective Presentation to Decision Makers
 - Collaborative Access/Security
- Specific to Model Integration
 - Model/Data Management
 - Control
 - Distributed Processing
 - Scalability and Speed

Moving Away from Excel/PowerPoint Systems Engineering

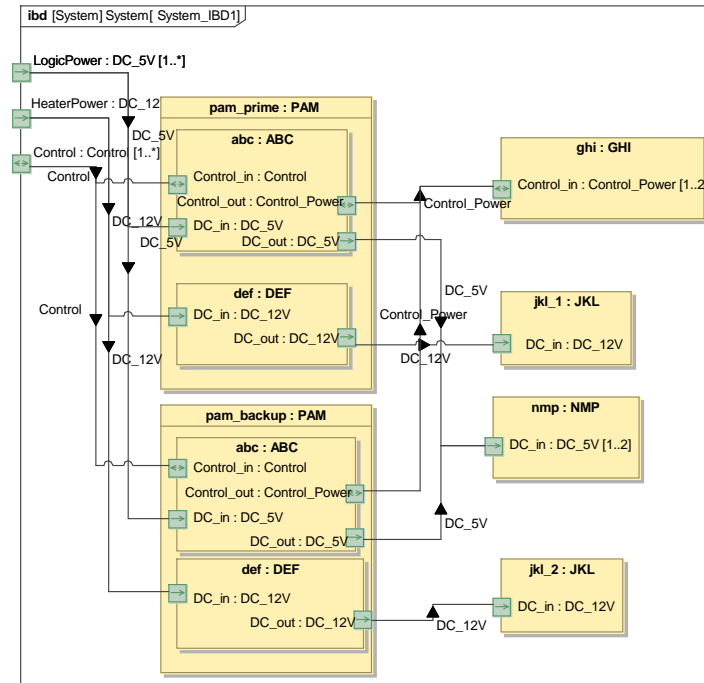
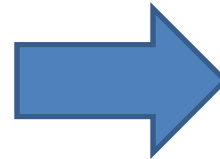
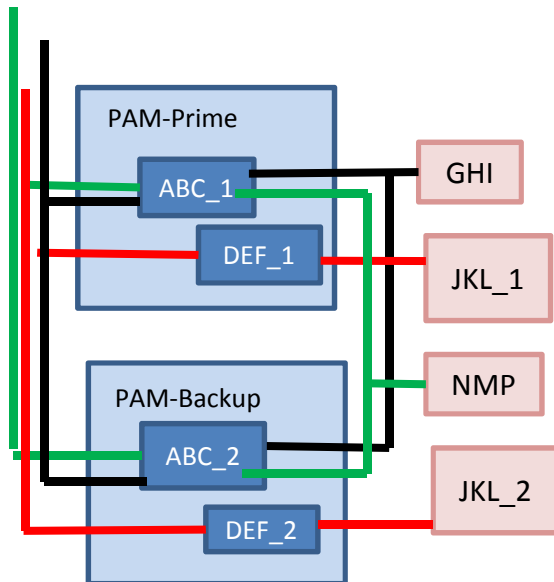

Traceability, Consistency, Transparency

Users won't give up

- Qualified Methodologies and Processes
- Standard Documents
- Legacy Software Tools
- Familiar Nomenclature and Symbols
- Validated Simulation Models

So any MBSE approach must supply methodologies, libraries, repositories, ... that are familiar to the organization

Energy and Infrastructure

- Smart Grid and Alternative Energy Sources
- Urban Sustainability and Resilience

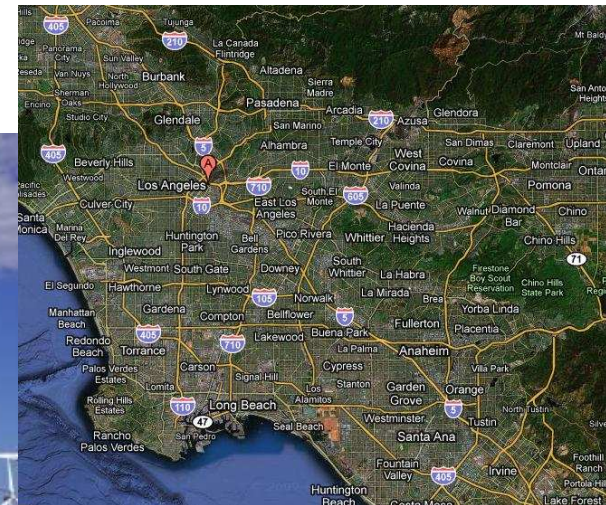

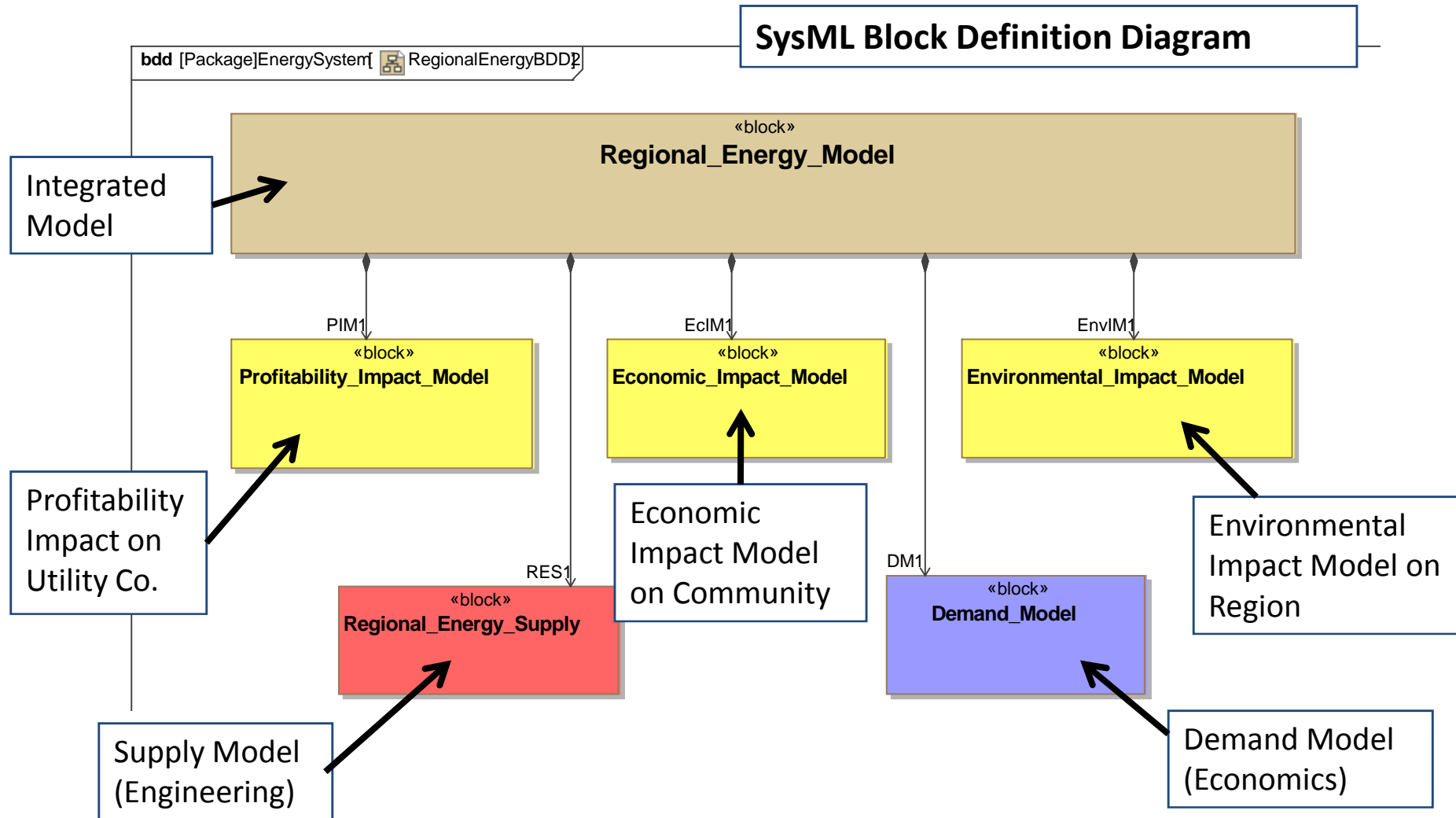

- **Integration of Structure and Behavior Simulation**
- **Integration of Programmatics**
 - Budget
 - Scheduling
 - Compliance

Dirk Zwemer

InterCAX LLC

75 Fifth Street NW, Suite 213

Atlanta, GA 30308

Voice: +1-404-592-6897, Ext 101

Email: dirk.zwemer@intercax.com

Web: www.intercax.com

www.magicdraw.com/sysml